

Applications Overview in the Interactive European Grid

Isabel Campos Plasencia / Celso Martínez Rivero

for the NA3 team

Kick-off Meeting int.eu.grid

Santander, 19th-23rd June

● Identification and support for Interactive Grid-Enhanced Applications



- Definition of the requirements and possibilities for interactivity for each application considered
- Setup of Virtual Organization support in coordination with SA1
- Consideration of Middleware adaptation and integration requirements, in coordination with JR activities
- Promote and support a high quality collaborative environment
- Evaluate the improvement on the execution of the application and the associated benefits
- Disseminate the results in the concerned areas

<http://wiki.fzk.de/i2g> → Design Documents

● Understanding the Application

- Description in terms of
 - Area of knowledge and status of the art
 - Results expected and impact on the scientific community
 - Understanding the computational approach at the algorithmic level
- Resources needed
 - Software & Hardware
 - GRID services
- GRID added value
 - Why on the GRID ?

● Interactive environment

● Graphics & Visualization

● Quality of Service regarding network reliability

Porting applications to *int.eu.grid*

● Relevant questions

- What is the advantage of using interactively the GRID ?
 - Understand the special constraints coming from steering if it exists
 - Realistic expectation for visualization possibilities
- How will the porting process work in terms of
 - Manpower/know-how
 - Experience of the people involved in porting applications
 - Has the application already run on any Grid in batch mode ?

→ A realistic roadmap has to be defined

● The success of the application is measured by

- Demonstrations/Proofs-of-concept in the project framework
- Engagement of users
- Technical publications (Computing Journals)
- Area related publications (Physics/Medical/... Journals)
- Impact on the general public

ATLAS online monitoring and calibration system



● Description

- QoS network application
- Distributes ATLAS events over a number of sites for analysis at a rate of 12 Mb/s
- Analyzes the network efficiency of the local sites in processing/dispatching data

● GRID added value

- It is an application specifically designed for the grid QoS testing

● Interactivity needs

- Allocate more resources runtime if the Network is observed to collapse

● Visualization

- inspection of events arrival rate (few Kbytes/s)

● The application potentially spans over the ATLAS VO

● Users

- ATLAS experiment operators

ATLAS online monitoring and calibration system

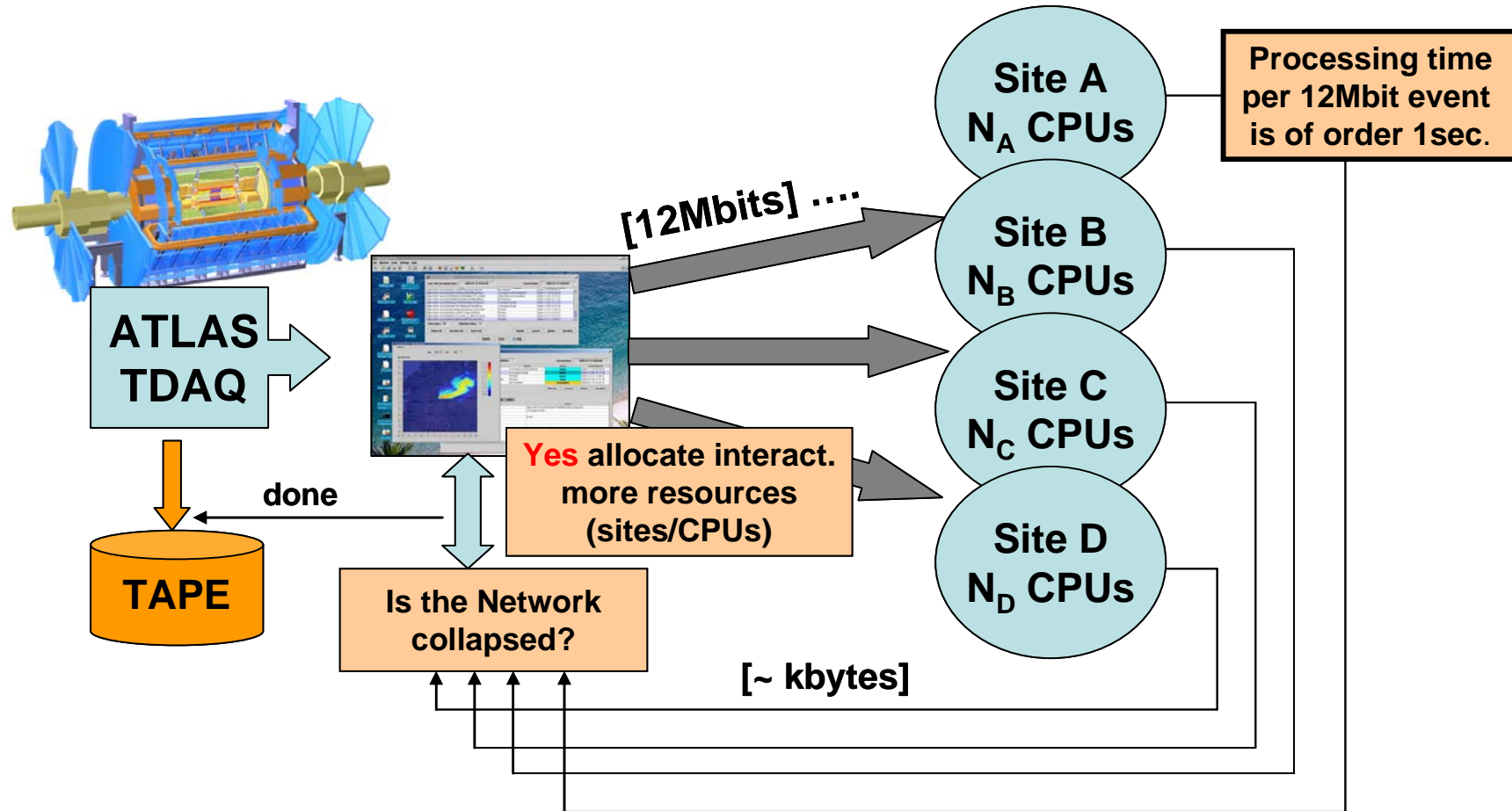

Visualization of Plasma in Fusion Reactors



● Description

- ❖ The application visualizes the behaviour of plasma inside a Fusion Reactor
- ❖ Runs are foreseen as a part of a so called *Fusion Virtual Session*
- ❖ The plasma is analyzed as a many body system consisting of N particles
- ❖ The N particles are distributed among a number of processors, which calculate the individual trajectories (independent)
- ❖ For every particle the position, velocity, etc... is stored in a binary file which is transmitted for visualization purposes

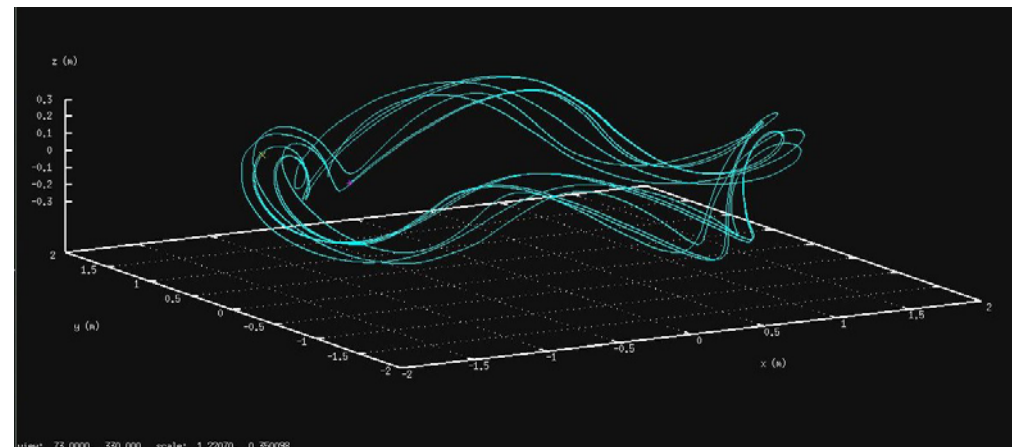

Visualization of Plasma in Fusion Reactors



- **Interactivity**

- ❖ Possibility of allocating more resources in runtime
- ❖ Changing the simulation physical parameters

- **Visualization**

- ❖ Graphical interface to visualize the plasma trajectory in the reactor
- ❖ Minimum Bandwidth for visualization 30 Mb/s

- **GRID added value**

- ❖ Gathering for short periods of time a large amount of resources

- **Users:** scientist from BIFI and CIEMAT

- **Resources:** computing clusters

- **Scientific outcome**

- ❖ Publications in Fusion technology Journals
- ❖ Participation in technical reports of Stellerator design

Visualization of Plasma in Fusion Reactors

FUSION VIRTUAL SESSION

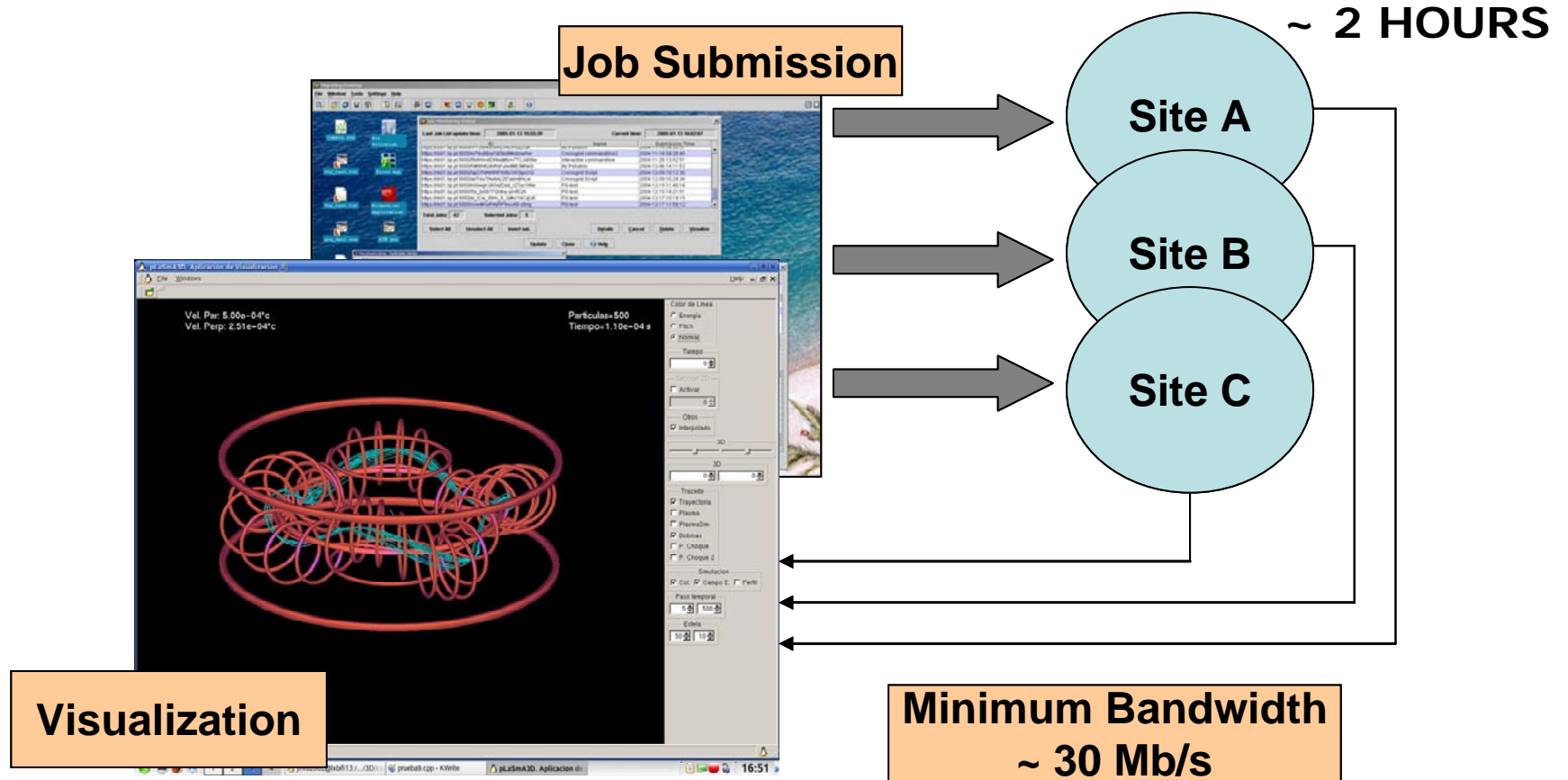

● Description

- Medical imaging application based on the reconstruction by numerical techniques of an image, using as input the data measured by a Ultra Sounds Scanner
- The Data measured in the scanner (~ 20 GB) are distributed for analysis over the grid
- Runs, which are in principle independent, are supposed to take about 30 minutes spanning over a large enough amount of CPUs.
- At completion, the results (total ~ 4 GB) are send back to the server

● Interactivity

- Beginning/End of the simulation

● Visualization

- *Matlab* graphical output → Java

- **GRID added value**

- Gather a large amount of resources to be able to solve a complex problem, which due to the nature of medical work, is severely time constrained

- **Users**

- Hospital analysis

- **Resources**

- Computing clusters
- At times large amount of data

- **Scientific Output**

- Development of new analysis techniques for clinical purposes
- Publications in journals related to computing tools for medical imaging
- Big impact at the social level

Ultra Sound Computer Tomography

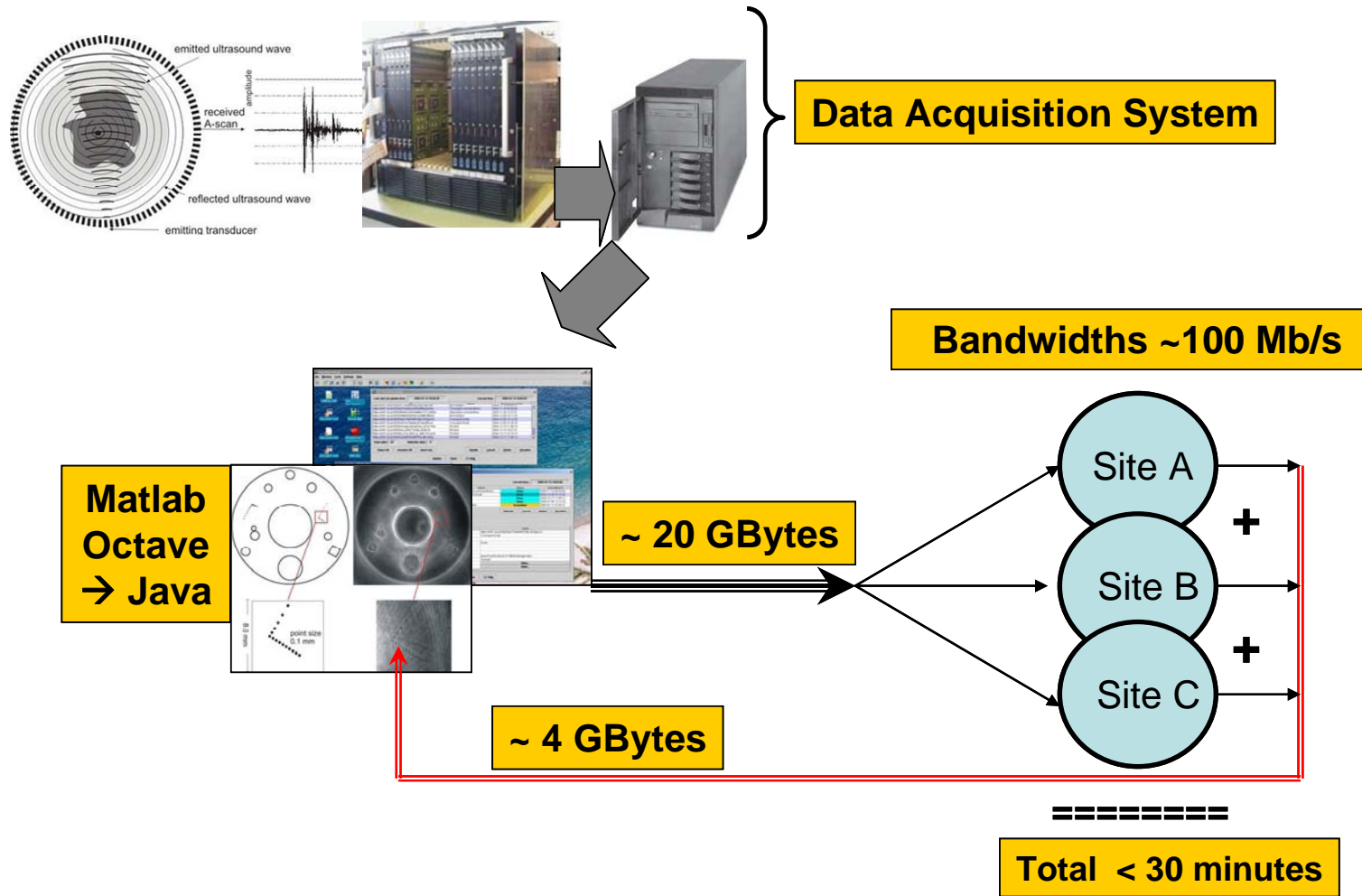

● Description

1. Modelling the impact of climate change scenarios on landscapes → **MPI data parallel**
2. Processing and visualize the dispersion in the atmosphere of pollutant agents: IMS Model
3. Meteorological combined with hidraulic simulations to predict risks associated to flooding → **MPI simulation**

● Interactivity

- Marginally on landscape modelling and IMS

● Visualization (BW up to 100 Mb/s)

1. Landscapes evolution
2. Dispersion map of a particular agent
3. Hydraulic maps of areas, flooding,...

Environmental Assessment of Climate-Change driven risks in Landscape

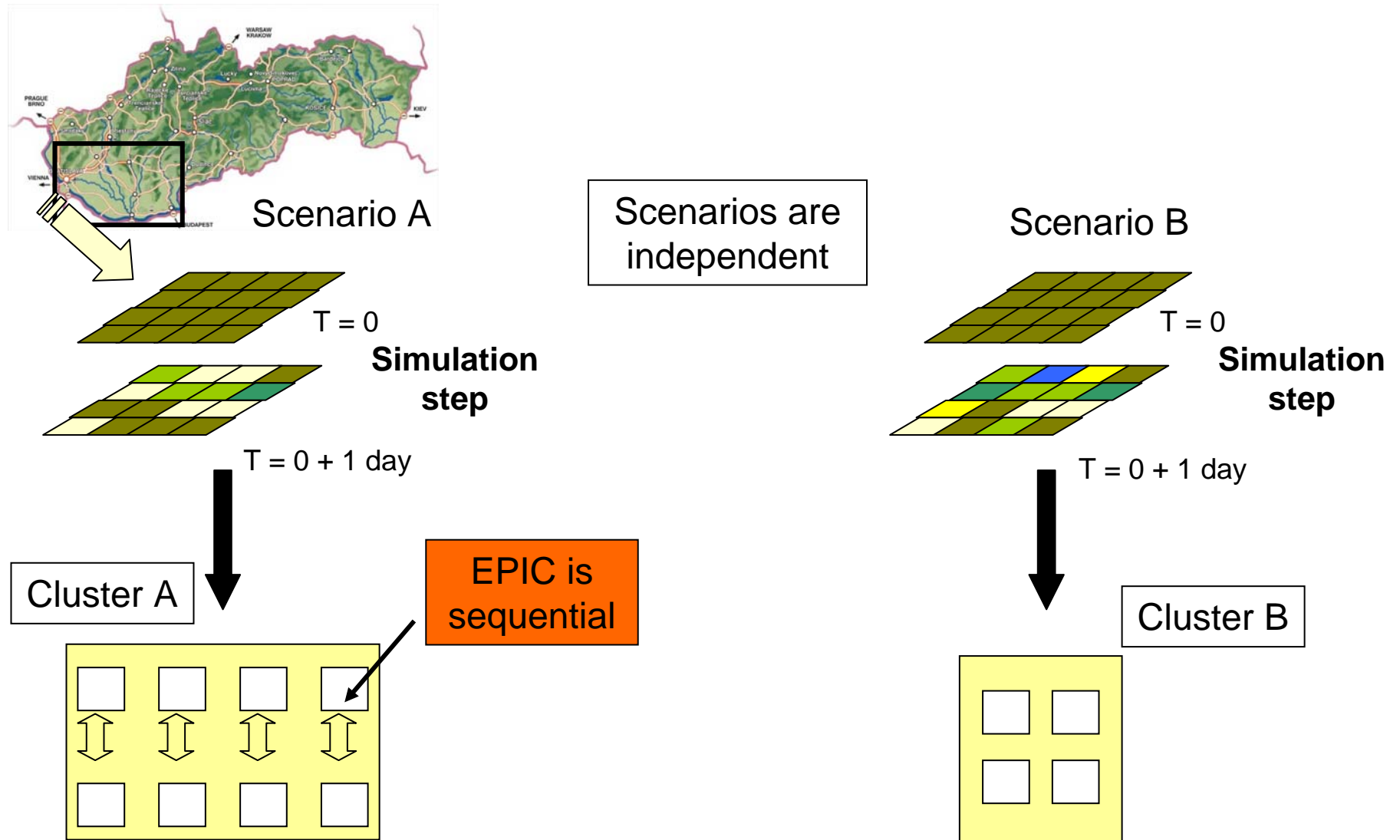

Some applications under consideration



- Physics
 - Image analysis of data coming from the Planck mission
- Medical applications
 - Brain Study applications
(Hospital Marqués de Valdecilla, Santander)
 - Portal based development repository
 - 3D visualization setup
 - Access Grid (including videoconference)
 - Many interesting visualization problems

- Most applications presented up to now are interested in a graphical representation of results
- Graphical **visualization along the run**
 - HEP ATLAS VO → up to few Kb/s constantly
 - Fusion → ~30 Mb/s constantly
 - Climate change Landscape risks
 - IMS (pollution evolution) → ~ few MB/s
- Only at the **beginning/end of the run**
 - USCT (3.2GB all at all)
 - Flooding Risk (30-100 MB end of the run)
 - Wave modelization (beginning of the run)

Networking QoS

- We have an application specifically to measure this issue: the **ATLAS TDAQ application**
- The rest of applications send/receive data occasionally:
 - The Bandwidth requirement is always under 100 Mb/s
 - Tolerable delays over 30 ms
 - No “chatty” applications
 - No sensitivity to jittering
 - No sensitivity to packet loss
 - No real need for dual paths
 - No streaming